

KW903-SP



SYNCHRO RETRANSMISSION UNIT

The KW903-SP interface converts serial heading data from a modern gyro to a high power Synchro signal with a ratio of 360:1 or 360X. Applications include refitting a ship with a new gyro, whilst retaining the existing repeaters. The majority of older commercial Synchro gyro systems have a ratio of 360:1 or 1 revolution per degree. Other ratios are catered for by the KW903-SX medium power model.

HEADING INPUTS All valid NMEA 0183 heading sentences, which most modern gyros give as standard and will also accept Step signals 6 steps per degree.

SYNCHRO OUTPUT

The "standard" and most common output is nominally 115v (50/60 Hz) reference, 90v line-to-line maximum voltage. The KW903 has several transformer configurations. The output is generated by solid-state techniques. The Synchro output rotates through 24 states per revolution with zero current software controlled switching technique.

SPECIAL CASE: YOKOGAWA

Yokogawa gyros normally use a DC supply to the Synchro, but they are still 115v/90v AC Synchro. The KW903-SP can be used without any modification to the voltage.

SPECIAL CASE: KURS RUSSIAN GYRO

Most KURS gyros have low power repeaters similar to Microtechnica with no problem. For KURS gyros that have very high power repeaters. These repeaters draw high current and are limited to 3 repeaters.

SAFETY FEATURES

The KW903-SP has an internal relay contact, which close in a fault condition. The local alarm has to be cleared by an onboard toggle switch. The KW903-SP can detect faults in the stepper or NMEA input signals, and if the Synchro output has been overloaded.

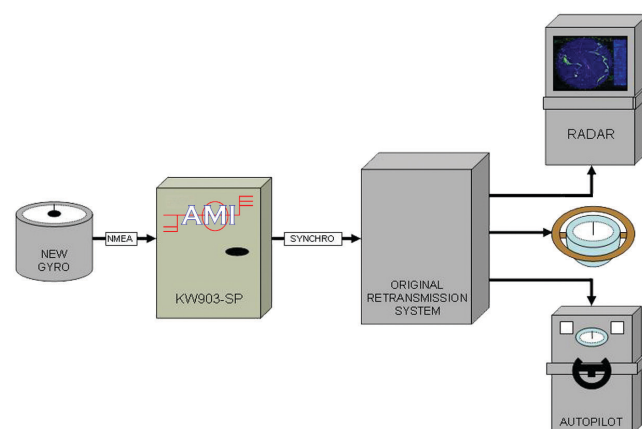

World Leaders
in Marine Interfacing
and Retransmission
Solutions

AMI Marine (UK) Ltd
Unit 2 Tower Industrial Estate,
Tower Lane, Eastleigh, Southampton,
Hampshire, UK SO50 6NZ
Tel: +44 (0) 2380 480450
sales@amimarine.net
service@amimarine.net

www.amimarine.net



KW903-SP



CHECK OF EXISTING REPEATERS

When replacing a defective gyro it is essential to check the existing repeaters. One stalled repeater can affect the whole system. All repeaters and the autopilot should be mechanically checked, including the Synchro brushes.

SPECIFICATION

- INPUT 1:** Stepper, 4 to 70 volt + or - polarity.
or NMEA 0183 Heading.
- INPUT 2:** NMEA 0183 heading, and all valid heading NMEA
(magnetic, Cetrek data).
- OUTPUT:** Nominal 115v ref, 90v signal, or 110v ref, 55v signal, or
50v ref, 68v signal.
For Anschutz 50/60v ref 20/24v signal an Anschutz Adaptor
is required and should be specified on ordering.
Reference output 2 Amp.
(Fit external transformer if more current required)
Phase output 0.7 Amps per phase. Limited at 2A.
Synchro output is removed if overload detected.
- ALARM RELAY:** Held open when OK.
Closes on power failure or when alarm is disabled.
Pulses when KW903 detects gyro fault, or output overload.
- CONTROLS:** Input 1, Input 2 changeover switch.
Alarm cancel/on/off switch
Main on/off switch. Rotation rate and test select hex switch.
- POWER:** Nominal 110/220v 50/60Hz at 600VA. Earth is essential.
- ENCLOSURE:** Dimensions 400 x 500 x 150mm electrical cabinet with door
for indoor bulkhead mounting. It should be fitted in a well
ventilated location. Not suitable for external use.
- APPROVALS:** IEC60945



World Leaders
in Marine Interfacing
and Retransmission
Solutions

AMI Marine (UK) Ltd
Unit 2 Tower Industrial Estate,
Tower Lane, Eastleigh, Southampton,
Hampshire, UK SO50 6NZ
Tel: +44 (0) 2380 480450
sales@amimarine.net
service@amimarine.net

www.amimarine.net

